

BLD750 Brushless DC Motor Drive

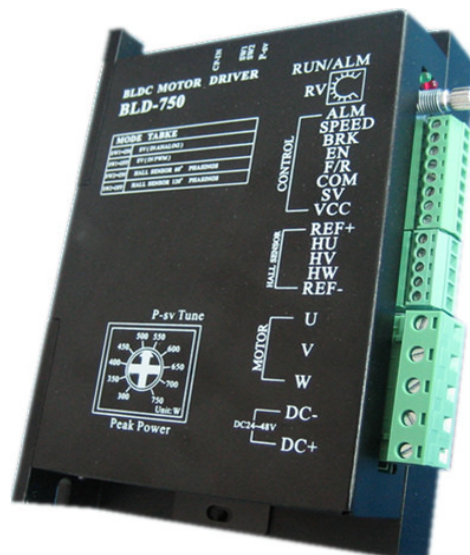

Description

The BLD750 BLDC motor drive is a high performance, cost-effective 3phase BLDC motor drive, which can provide power output Max 750VA. The design is based on advanced DSP technology and feature high torque, low noise, low vibration, PID speed loop, PID current loop, over current protection, over load protection and a combined use of manual speed adjustment and automatic speed adjustment.

Connection Definition

Mark	Definition
DC+/DC-	DC Power Input (DC24V~DC48V)
U,V,W	Motor Lead Wire
Hu,Hv,Hw	Hall Sensor Lead Wire
REF+	Hall Sensor Power Supply +
REF-	Hall Sensor Power Supply -
VCC	External Potentiometer Power Supply (Internal Power Supply Only)
SV	External Potentiometer (No Connection When Adjusting Speed With Internal Potentiometer) or Pulse Rate In Note ①
COM	Common (Low Level/Ground)
F/R	Direction: Low Level/CCW High Level or No Connection/CW Note ②
EN	Enable: High Level/Stop Low Level/Run Note ②
BRK	Quick Brake: High Level/Stop Low Level/Run Note ②
SPEED	Speed Signal Output
ALARM	Alarm Signal Output

Note①: Potentiometer/10K Ω or analog signal DC 0V~+5V (Change internal switch J1/DC0-10V). Turn off the internal potentiometer RV when using an external potentiometer to adjust the motor speed.

Note②: High level/5V (5mA)

Electrical Specifications

Parameter	Min	Rated	Max	Unit
Motor Hall Sensor Angle	120°/240°			
DC Power Input	18	48	50	V
Drive Current Output	0	25	45	A
Suitable Motor Speed	0		20000	rpm
Hall Sensor Voltage	4.5	5	5.5	V
Hall Sensor Current		20		mA
External Potentiometer		10K		Ω

Peak Power Output Setting:

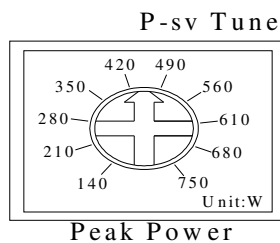

Note: To protect the motor, set the arrow number as the same as the motor nominated power. Whenever overload occurs the drive will turn out to be the protection mode.

Connection:

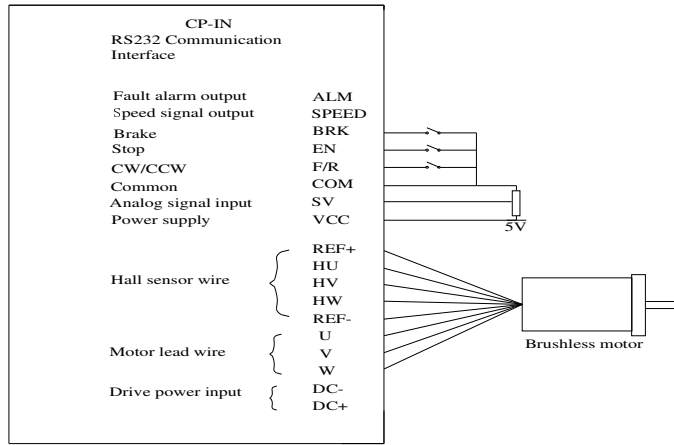

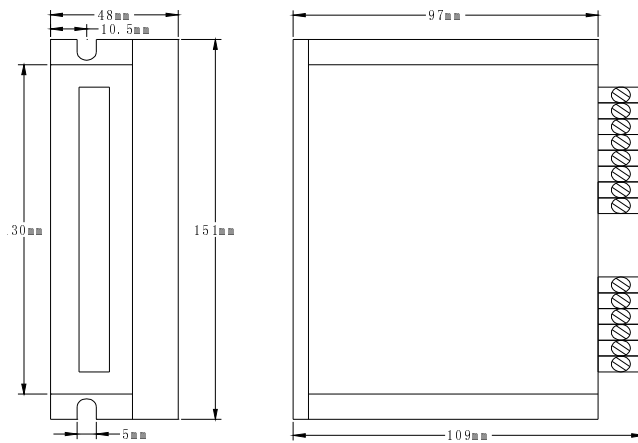

Mechanical Drawings:



Speed Adjustment Instruction:

- **Motor Speed Adjusted By The Internal Potentiometer RV:**

SW1/ Off (Factory setting)

- **Motor Speed Adjusted By Analog DC 0V~+5V Input:**
SW1/ Off (Factory setting) set J1 (internal) as  (user Setting)
RV—Turn Off
- **Motor Speed Adjusted By Analog DC 0V~+10V Input:**
SW1/ Off (Factory setting) set J1 (internal) as  (user Setting)
RV—Turn Off
- **Motor Speed Adjusted By Pulse Rate Input:**
Pulse rate: 0K—3KHZ Speed linear modulation
Pulse amplitude: 5V Pulse duty ratio: 50%
SW1/ On (User setting) RV—Turn Off
J7 (Internal)/ Switch on with the jumper cap on J1 (User setting)
- **Motor Speed Quick Response Setting:**
SW2/ On (User setting): PID closed loop--quick speed response
SW2/Off (Factory setting): Open loop--Normal speed response
- **Motor Speed Signal Output:**
Connecting SPEED and COM to get pulse output $F=N*P/60$
F—Pulse output frequency
P—Pole number of BLDC motor
- **Drive Alarm Output:**
When drive alarm, it will break over with the port of COM and be low level. The drive stop to work and alarm light run.
- **Lead Wire Connection:** Take care of the sequence of U,V,W

Motor Parameter set by ICAN BLDD-01 (Optional) :

- **RS232 Communication Interface CP-in**
The BLDD48-45A BLDC motor drive support RS232 communication Protocol to set motor run-up time, etc. When choose ICAN BLDD-01 as host controller, the operating process and instruction as below:
- **ICAN BLDD-01 Motor Setting Panel Operating Process:**
Connect to CP-in (BLDD48-45A)
SW1/ Off (Factory setting) RV—Turn Off

BLDD-01 Parameter Setting Table:

Function code	Mode	Setting range	Unit	Factory setting	Alteration
P000	Control mode	00 BLDD-01 control 01 None host control		None Panel control	★
P001	Panel setting speed	0~Rated speed	RPM		★
P002	Run-up time	0.1~9.9	S	0.2	★
P003	Motor pole number setting	1~99	Pole pairs	4	★
P004	CW CCW	01 CW 00 CCW		01	★
P005					Reserved
P006					Reserved

- **BLDD-01 Panel Setting Process:**

1. Turn on the power supply, press <Set> to stop the motor
2. Press <▲> or <▼> to choose the mode you need (Press Esc return and motor running)
3. Press <Set> enter into parameter mode (Press Esc return and motor running)
4. Press <◀> or <▶> to change the parameter (flashing)
5. Press <Set> to reserve, parameter stop to flash. Press <Esc> return and motor running.

Panel Protection Mode:

When the system running, panel nixie light shows **Errx**

Err0 represents Over-voltage or Over-temperature protection

Err1 represents Over-current protection

Err2 represents Hall sensor error protection

- **Motor Parameter set by other host controller:**

BLDD48-45A Communication Protocol (RS232)

1. Communication Interface:

Asynchronous serial communication

Baud rate: 2400

Start bit: 1 bit

Stop bit: 1 bit

Data bit: 8 bits

Even/odd parity: none

Communication interface voltage: 3.3V

2. Communication Protocol:

Function1: Motor speed controlled by drive BLD-750 itself

Communication format : "i"

Instruction: send a character

Function2: Motor speed controlled by host computer

Communication format: "o"

Instruction: send a character

Function3: Motor speed set by host computer

Communication format: "v"0X00, 0X00

Instruction: send a character "v" then two hexadecimal numbers
the high 16bits, the low 16 bits

Function4: run-up time

Communication format: "y" 0X00

Instruction: send "y" then a hexadecimal number